

Packing List

- 1- Chevrolet Camaro T4 SS Front Splitter
- 3 - M8x1.25 x20 Bolts
- 6 - M8 Washer
- 3 - M8 Nut
- 11 - Clips
- Instructions
- Proudly Packaged by _____



ACS T4 Splitter for Camaro SS, PN 33-4-099

The T4 logo is rendered in a bold, italicized, red font.

1. Observe proper precautions and safety procedures while performing the following.
2. Raise vehicle to a comfortable working height.

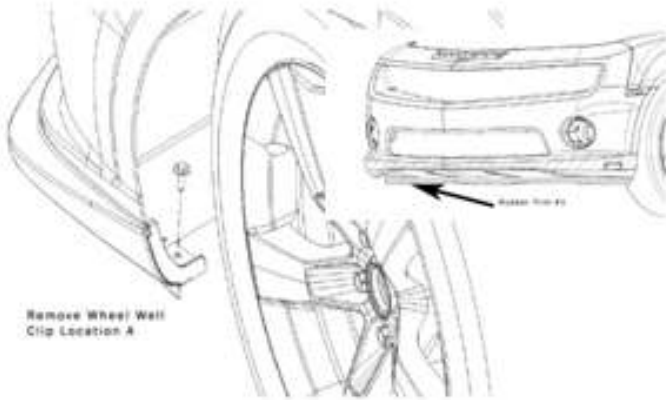

3. Remove clip located at each extremity of the bumper in front of the front wheel.

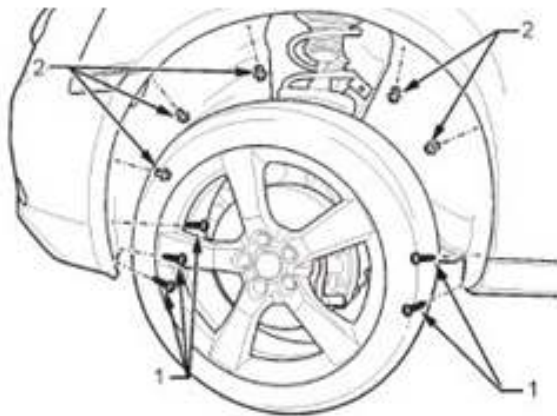

- (Optional: This step is to install M8 fasteners described in step 9) otherwise you can use the additional supplied scrivenets.

5. Remove the front wheel well liner by removing three screws from the front and two screws from the rear of the liner (1). Use a trim release tool to remove five scrivenets (2), remove the liner. Repeat Steps on the RHS of the vehicle.

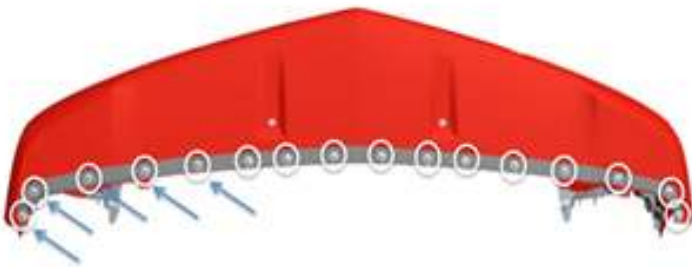

4. Remove the under carriage rubber seal located at the end of the fascia. Save the clips and seal. These will be reinstalled once the T4 splitter is mounted.

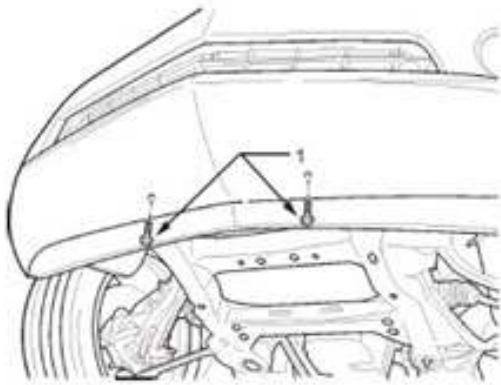

5. Remove two 10 mm bolts located in the center of the fascia. Save these, as they will be reused to mount the T4 Splitter.



6. Position the splitter onto the fascia. You may need an assistant's help or clamps to hold in position.

ICS T4 Splitter for Camaro SS, PN 33-4-099

T4



acscomposite.com

7. Install the two center 10 mm bolts. At this point you will need to ensure the splitter is properly located. It needs to be flush at both extremities and centered. If need be, slightly enlarge the center holes. Temporarily fasten a M8 nut and bolt on the extremities. (Circled position in image) both the driver's and passenger end.

(These are purely used to help you locate the splitter).

At this point splitter should be flush at both extremities.



9. Remove M8 bolt from step 7 and reinstall in the circled position. M8 bolt and washers need to be installed at circled positions.



8. Using the Splitter as a template and starting from the centre drill an 8 mm (5/16") diameter holes and install a pressure clip, ensure the fascia and splitter are close together.

Continue drilling holes alternating each side and installing clips.



10. Reinstall the rear rubber deflector using the original fasteners.

Reverse step 5 to reinstall the wheel well liner.

11. Congratulations! Installation is now complete. We invite you to share images on our Facebook Page. Simply search:

Advanced Composite Specialties.

Also join us on Camaro5.com, the largest online 5th gen community.

For questions or comments please email us at:

info@acscomposite.com